

TANDRIEMPOELIES

L-050

riem • steek $L = 3/8'' = 9,525 \text{ mm}$
 • breedte 050 = $1/2'' = 12,7 \text{ mm}$

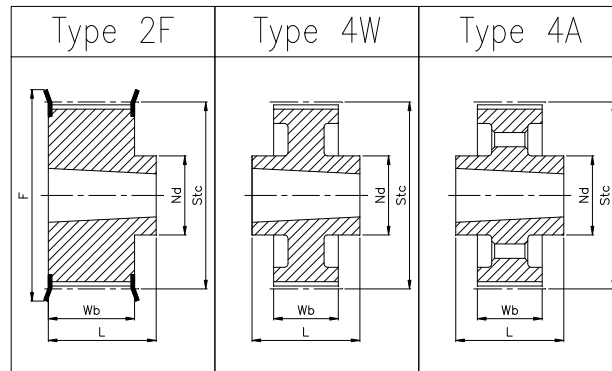

KTN CODE				Taper spanbussen + max. boring	Steek cirkel Stc [mm]	Flens diameter F [mm]	Wiel breedte Wb [mm]	Lengte L [mm]	Naaf diameter Nd [mm]	Gewicht ca. [kg/stuk]	Materiaal *
Aantal Tandem z	Steek	Riem breedte	Type								
18	L	050	2F	1108-28	54,57	60	19	22	44	0,17	St
19	L	050	2F	1108-28	57,61	64	19	22	44	0,21	St
20	L	050	2F	1108-28	60,64	66	19	22	46	0,25	St
21	L	050	2F	1108-28	63,67	71	19	22	48	0,30	St
22	L	050	2F	1108-28	66,70	75	19	22	51	0,35	St
23	L	050	2F	1108-28	69,73	79	19	22	54	0,41	St
24	L	050	2F	1108-28	72,77	79	19	22	54	0,46	St
25	L	050	2F	1108-28	75,80	83	19	22	54	0,52	St
26	L	050	2F	1108-28	78,83	86	19	22	60	0,58	St
27	L	050	2F	1108-28	81,86	91	19	22	64	0,58	GG
28	L	050	2F	1108-28	84,89	91	19	22	64	0,63	GG
30	L	050	2F	1108-28	90,96	97	19	22	73	0,76	GG
32	L	050	2F	1108-28	97,02	103	19	22	76	0,89	GG
36	L	050	2F	1108-28	109,15	114	19	22	76	1,16	GG
40	L	050	2F	1610-42	121,28	128	19	25	89	1,35	GG
44	L	050	2F	1610-42	133,40	140	19	25	89	1,77	GG
48	L	050	2F	1610-42	145,53	152	19	25	114	2,30	GG
60	L	050	4W	1610-42	181,91	--	19	25	92	1,82	GG
72	L	050	4A	1610-42	218,30	--	19	25	92	1,97	GG
84	L	050	4A	1610-42	254,68	--	19	25	92	2,33	GG
96	L	050	4A	2012-50	291,06	--	19	32	111	3,46	GG
120	L	050	4A	2012-50	363,83	--	19	32	111	4,68	GG

* St = staal
 GG = gietijzer

TANDRIEMPOELIES

L-075

riem • steek $L = 3/8'' = 9,525 \text{ mm}$
 • breedte $075 = 3/4'' = 19,05 \text{ mm}$

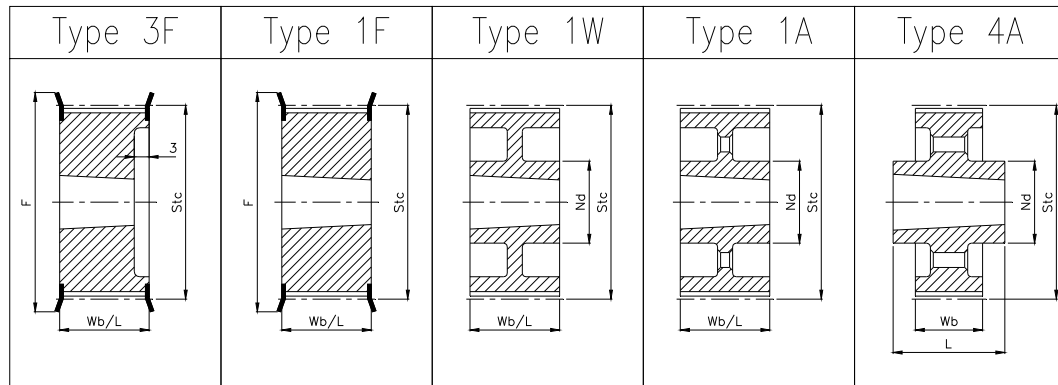

KTN CODE				Taper spanbussen + max. boring	Steek cirkel S1c [mm]	Flens diameter F [mm]	Wiel breedte Wb [mm]	Lengte L [mm]	Naaf diameter Nd [mm]	Gewicht ca. [kg/stuk]	Mate- riaal *
Aantal Tanden z	Steek	Riem breedte	Type								
18	L	075	3F	1108-28	54,57	60	25	25	--	0,21	St
19	L	075	3F	1108-28	57,61	64	25	25	--	0,26	St
20	L	075	3F	1108-28	60,64	66	25	25	--	0,31	St
21	L	075	3F	1108-28	63,67	71	25	25	--	0,37	St
22	L	075	3F	1108-28	66,70	75	25	25	--	0,42	St
23	L	075	3F	1108-28	69,73	79	25	25	--	0,48	St
24	L	075	3F	1108-28	72,77	79	25	25	--	0,55	St
25	L	075	3F	1108-28	75,80	83	25	25	--	0,61	St
26	L	075	3F	1108-28	78,83	86	25	25	--	0,66	St
27	L	075	3F	1108-28	81,86	91	25	25	--	0,67	GG
28	L	075	3F	1108-28	84,89	91	25	25	--	0,73	GG
30	L	075	3F	1108-28	90,96	97	25	25	--	0,86	GG
32	L	075	3F	1108-28	97,02	103	25	25	--	1,01	GG
36	L	075	1F	1610-42	109,15	114	25	25	--	1,27	GG
40	L	075	1F	1610-42	121,28	128	25	25	--	1,66	GG
44	L	075	1F	1610-42	133,40	140	25	25	--	2,09	GG
48	L	075	1F	1610-42	145,53	152	25	25	--	2,56	GG
60	L	075	1W	1610-42	181,91	--	25	25	92	1,95	GG
72	L	075	1A	1610-42	218,30	--	25	25	92	2,23	GG
84	L	075	4A	2012-50	254,68	--	25	32	111	3,22	GG
96	L	075	4A	2012-50	291,06	--	25	32	111	3,87	GG
120	L	075	4A	2012-50	363,83	--	25	32	111	5,28	GG

* St = staal

GG = gietijzer

TANDRIEMPOELIES

L-100

riem • steek $L = 1/2'' = 12,7 \text{ mm}$
 • breedte $100 = 1'' = 25,4 \text{ mm}$

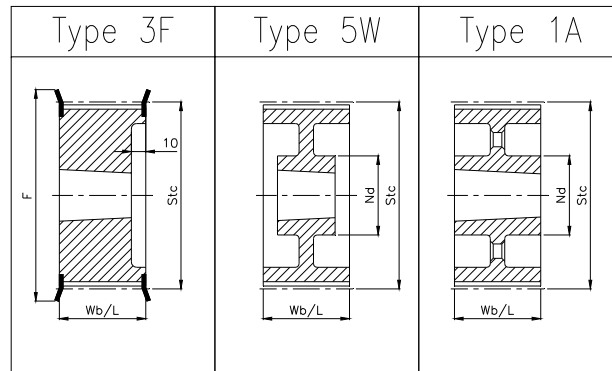

KTN CODE				¹ maat 10 = 7 mm								
Aantal Tandem z	Steek	Riem breedte	Type	Taper spanbussen + max. boring	Steek cirkel Stc [mm]	Flens diameter F [mm]	Wiel breedte Wb [mm]	Lengte L [mm]	Naaf diameter Nd [mm]	Gewicht ca. [kg/stuk]	Materiaal *	
18	L	100	3F	1108-28	54,57	60	32	32	--	0,27	St	
19	L	100	3F	1108-28	57,61	64	32	32	--	0,34	St	
20	L	100	3F	1108-28	60,64	66	32	32	--	0,37	St	
21	L	100	3F	1108-28	63,67	71	32	32	--	0,45	St	
22	L	100	3F	1108-28	66,70	75	32	32	--	0,51	St	
23	L	100	3F	1108-28	69,73	79	32	32	--	0,57	St	
24	L	100	3F	1108-28	72,77	79	32	32	--	0,66	St	
25	L	100	3F	1108-28	75,80	83	32	32	--	0,72	St	
26	L	100	3F	1108-28	78,83	86	32	32	--	0,78	St	
27	L	100	3F	1108-28	81,86	91	32	32	--	0,79	GG	
28	L	100	3F	1108-28	84,89	91	32	32	--	0,85	GG	
¹ 30	L	100	3F	1210-32	90,96	97	32	32	--	0,89	GG	
¹ 32	L	100	3F	1210-32	97,02	103	32	32	--	1,05	GG	
¹ 36	L	100	3F	1610-42	109,15	114	32	32	--	1,43	GG	
¹ 40	L	100	3F	1610-42	121,28	128	32	32	--	1,75	GG	
¹ 44	L	100	3F	1610-42	133,40	140	32	32	--	2,20	GG	
¹ 48	L	100	3F	1610-42	145,53	152	32	32	--	2,70	GG	
60	L	100	5W	1610-42	181,91	--	32	32	92	2,12	GG	
72	L	100	1A	2012-50	218,30	--	32	32	111	2,95	GG	
84	L	100	1A	2012-50	254,68	--	32	32	111	3,57	GG	
96	L	100	1A	2012-50	291,06	--	32	32	111	4,31	GG	
120	L	100	1A	2012-50	363,83	--	32	32	111	5,95	GG	

* St = staal
 GG = gietijzer

TANDRIEMPOELIES

H-100

riem • steek $H = 1/2'' = 12,7 \text{ mm}$
 • breedte $100 = 1'' = 25,4 \text{ mm}$

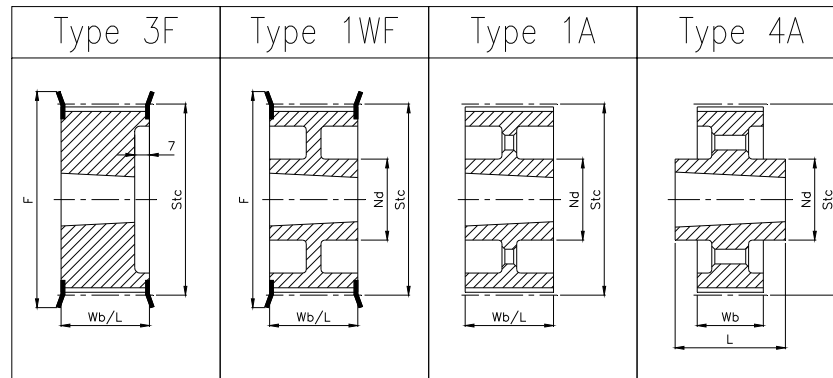

KTN CODE				¹ maat 7 = 10 mm								
Aantal Tandens z	Steek	Riem breedte	Type	Taper spanbussen + max. boring	Steek cirkel S1c [mm]	Flens diameter F [mm]	Wiel breedte Wb [mm]	Lengte L [mm]	Naaf diameter Nd [mm]	Gewicht ca. [kg/stuk]	Materiaal *	
¹ 16	H	100	3F	1108-28	64,68	71	32	32	--	0,46	St	
18	H	100	3F	1210-32	72,77	79	32	32	--	0,49	St	
19	H	100	3F	1210-32	76,81	83	32	32	--	0,59	St	
20	H	100	3F	1210-32	80,85	86	32	32	--	0,62	St	
21	H	100	3F	1210-32	84,89	91	32	32	--	0,71	St	
22	H	100	3F	1210-32	88,94	93	32	32	--	0,82	GG	
23	H	100	3F	1610-42	92,98	97	32	32	--	0,90	GG	
24	H	100	3F	1610-42	97,02	103	32	32	--	0,93	GG	
25	H	100	3F	1610-42	101,06	106	32	32	--	1,05	GG	
26	H	100	3F	1610-42	105,11	111	32	32	--	1,29	GG	
27	H	100	3F	1610-42	109,15	114	32	32	--	1,40	GG	
28	H	100	3F	1610-42	113,19	119	32	32	--	1,55	GG	
30	H	100	3F	1610-42	121,28	128	32	32	--	1,83	GG	
32	H	100	3F	1610-42	129,36	135	32	32	--	2,11	GG	
36	H	100	3F	1610-42	145,53	152	32	32	--	2,76	GG	
40	H	100	3F	1610-42	161,70	168	32	32	--	3,47	GG	
44	H	100	1WF	2012-50	177,87	184	32	32	111	3,10	GG	
48	H	100	1WF	2012-50	194,04	200	32	32	111	3,38	GG	
60	H	100	1A	2012-50	242,55	--	32	32	111	4,45	GG	
72	H	100	1A	2012-50	291,06	--	32	32	111	5,48	GG	
84	H	100	1A	2012-50	339,57	--	32	32	111	6,51	GG	
96	H	100	4A	2517-60	388,08	--	32	45	124	8,51	GG	
120	H	100	4A	2517-60	485,10	--	32	45	124	11,30	GG	
156	H	100	4A	2517-60	630,64	--	32	45	124	17,16	GG	

* St = staal

GG = gietijzer

TANDRIEMPOELIES

H-150

riem • steek $H = 1/2'' = 12,7 \text{ mm}$
 • breedte $150 = 1 \ 1/2'' = 38,1 \text{ mm}$

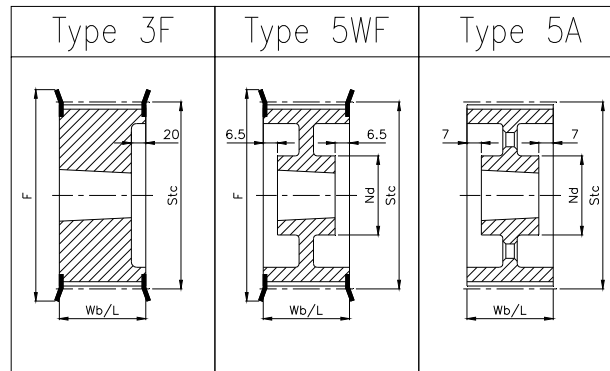

KTN CODE				¹ maat 7 = 0,5 mm							
Aantal Tanden z	Steek	Riem breedte	Type	Taper spanbussen + max. boring	Steek cirkel Stc [mm]	Flens diameter F [mm]	Wiel breedte Wb [mm]	Lengte L [mm]	Naaf diameter Nd [mm]	Gewicht ca. [kg/stuk]	Materiaal *
18	H	150	3F	1210-32	72,77	79	45	45	--	0,69	St
19	H	150	3F	1210-32	76,81	83	45	45	--	0,80	St
20	H	150	3F	1210-32	80,85	86	45	45	--	0,93	St
21	H	150	3F	1210-32	84,89	91	45	45	--	1,03	St
22	H	150	3F	1210-32	88,94	93	45	45	--	1,04	GG
23	H	150	3F	1610-42	92,98	97	45	45	--	1,09	GG
24	H	150	3F	1610-42	97,02	103	45	45	--	1,17	GG
25	H	150	3F	1610-42	101,06	106	45	45	--	1,30	GG
26	H	150	3F	1610-42	105,11	111	45	45	--	1,48	GG
27	H	150	3F	1610-42	109,15	114	45	45	--	1,59	GG
28	H	150	3F	1610-42	113,19	119	45	45	--	1,77	GG
30	H	150	3F	1610-42	121,28	128	45	45	--	2,07	GG
32	H	150	3F	1610-42	129,36	135	45	45	--	2,37	GG
36	H	150	3F	1610-42	145,53	152	45	45	--	3,07	GG
40	H	150	3F	1610-42	161,70	168	45	45	--	3,85	GG
44	H	150	5WF	2012-50	177,87	184	45	45	111	3,61	GG
48	H	150	5WF	2012-50	194,04	200	45	45	111	4,10	GG
60	H	150	5A	2012-50	242,55	--	46	46	111	5,37	GG
72	H	150	5A	2012-50	291,06	--	46	46	111	6,38	GG
84	H	150	5A	2012-50	339,57	--	46	46	111	7,78	GG
¹ 96	H	150	5A	2517-60	388,08	--	46	46	124	10,13	GG
¹ 120	H	150	5A	2517-60	485,10	--	46	46	124	13,91	GG
¹ 156	H	150	5A	2517-60	630,64	--	46	46	146	22,06	GG

* St = staal
 GG = gietijzer

TANDRIEMPOELIES

H-200

riem • steek $H = 1/2'' = 12,7 \text{ mm}$
 • breedte $200 = 2'' = 50,8 \text{ mm}$

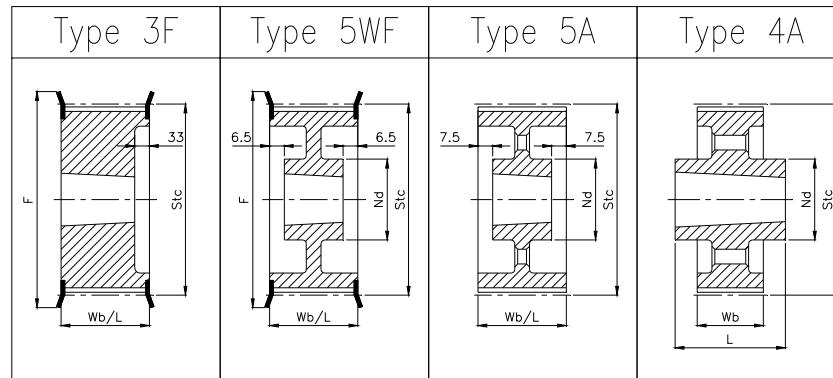

KTN CODE				¹ maat 33 = 26 mm	² maat 33 = 13 mm						
Aantal Tandem z	Steek	Riem breedte	Type	Taper spanbussen + max. boring	Steek cirkel S1c [mm]	Flens diameter F [mm]	Wiel breedte Wb [mm]	Lengte L [mm]	Naaf diameter Nd [mm]	Gewicht ca. [kg/stuk]	Materiaal *
18	H	200	3F	1210-32	72,77	79	58	58	--	0,88	St
19	H	200	3F	1210-32	76,81	83	58	58	--	1,01	St
20	H	200	3F	1610-42	80,85	86	58	58	--	1,06	St
21	H	200	3F	1610-42	84,89	91	58	58	--	1,15	St
22	H	200	3F	1610-42	88,94	93	58	58	--	1,16	GG
23	H	200	3F	1610-42	92,98	97	58	58	--	1,35	GG
24	H	200	3F	1610-42	97,02	103	58	58	--	1,40	GG
25	H	200	3F	1610-42	101,06	106	58	58	--	1,54	GG
26	H	200	3F	1610-42	105,11	111	58	58	--	1,78	GG
27	H	200	3F	1610-42	109,15	114	58	58	--	1,87	GG
28	H	200	3F	1610-42	113,19	119	58	58	--	2,09	GG
30	H	200	3F	1610-42	121,28	128	58	58	--	2,42	GG
¹ 32	H	200	3F	2012-50	129,36	135	58	58	--	2,76	GG
¹ 36	H	200	3F	2012-50	145,53	152	58	58	--	3,66	GG
¹ 40	H	200	3F	2012-50	161,70	168	58	58	--	4,65	GG
² 44	H	200	3F	2517-60	177,87	184	58	58	--	6,50	GG
48	H	200	5WF	2517-60	194,04	200	58	58	124	5,31	GG
60	H	200	5A	2517-60	242,55	--	60	60	124	5,84	GG
72	H	200	5A	2517-60	291,06	--	60	60	124	8,33	GG
84	H	200	5A	2517-60	339,57	--	60	60	124	9,84	GG
96	H	200	5A	2517-60	388,08	--	60	60	124	11,90	GG
120	H	200	5A	2517-60	485,10	--	60	60	146	19,12	GG
156	H	200	4A	3030-75	630,64	--	60	76	146	26,32	GG

* St = staal
 GG = gietijzer

TANDRIEMPOELIES

H-300

riem • steek $H = 1/2'' = 12,7 \text{ mm}$
 • breedte $300 = 3'' = 76,2 \text{ mm}$

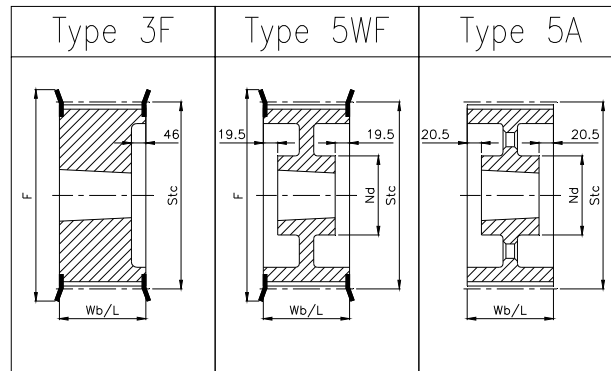

KTN CODE				¹ maat 46 = 52 mm	² maat 46 = 39 mm	³ maat 20,5 = 5 mm					
Aantal Tandens z	Steek	Riem breedte	Type	Taper spanbussen + max. boring	Steek cirkel Stc [mm]	Flens diameter F [mm]	Wiel breedte Wb [mm]	Lengte L [mm]	Naaf diameter Nd [mm]	Gewicht ca. [kg/stuk]	Materiaal *
20	H	300	3F	1615-42	80,85	86	84	84	--	1,54	St
21	H	300	3F	1615-42	84,89	91	84	84	--	1,67	St
22	H	300	3F	1615-42	88,94	93	84	84	--	1,69	St
23	H	300	3F	1615-42	92,98	97	84	84	--	1,96	GG
24	H	300	3F	1615-42	97,02	103	84	84	--	2,05	GG
25	H	300	3F	1615-42	101,06	106	84	84	--	2,26	GG
26	H	300	3F	1615-42	105,11	111	84	84	--	2,61	GG
¹ 27	H	300	3F	2012-50	109,15	114	84	84	--	2,32	GG
¹ 28	H	300	3F	2012-50	113,19	119	84	84	--	2,63	GG
¹ 30	H	300	3F	2012-50	121,28	128	84	84	--	3,00	GG
² 32	H	300	3F	2517-60	129,36	135	84	84	--	3,32	GG
² 36	H	300	3F	2517-60	145,53	152	84	84	--	4,59	GG
² 40	H	300	3F	2517-60	161,70	168	84	84	--	6,00	GG
² 44	H	300	3F	2517-60	177,87	184	84	84	--	7,54	GG
48	H	300	5WF	2517-60	194,04	200	84	84	124	6,54	GG
60	H	300	5A	2517-60	242,55	--	86	86	124	7,89	GG
72	H	300	5A	2517-60	291,06	--	86	86	124	10,00	GG
84	H	300	5A	2517-60	339,57	--	86	86	124	11,87	GG
³ 96	H	300	5A	3030-75	388,08	--	86	86	146	16,47	GG
³ 120	H	300	5A	3030-75	485,10	--	86	86	146	22,11	GG
³ 156	H	300	5A	3030-75	630,64	--	86	86	178	35,94	GG

* St = staal
 GG = gietijzer

TANDRIEMPOELIES

XH-200

- riem • steek $XH = 7/8" = 22,225$ mm
 • breedte $200 = 2" = 50,8$ mm

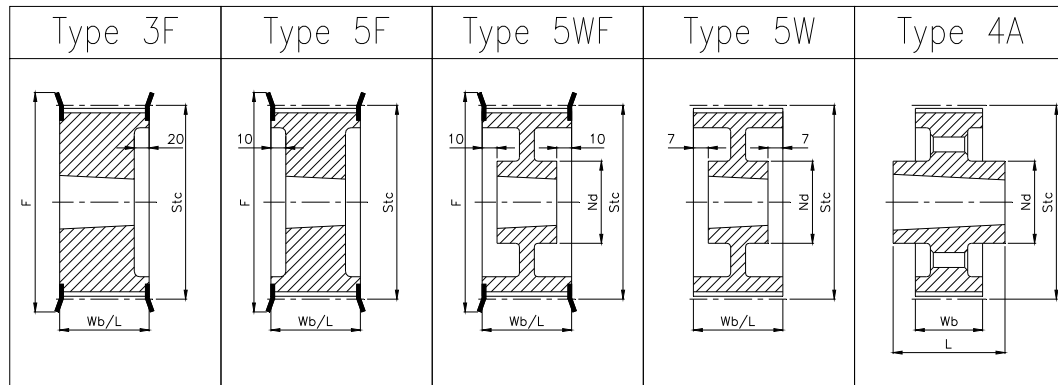

KTN CODE				¹ maat 10 = 7 mm							
Aantal Tandens <i>z</i>	Steek	Riem breedte	Type	Taper spanbussen + max. boring	Steek cirkel <i>S1c</i> [mm]	Flens diameter <i>F</i> [mm]	Wiel breedte <i>Wb</i> [mm]	Lengte <i>L</i> [mm]	Naaf diameter <i>Nd</i> [mm]	Gewicht ca. [kg/stuk]	Materiaal *
18	XH	200	3F	2517-60	127,33	142	65	65	--	2,60	GG
20	XH	200	3F	2517-60	141,48	155	65	65	--	3,60	GG
22	XH	200	3F	2517-60	155,63	170	65	65	--	4,80	GG
24	XH	200	3F	2517-60	169,80	184	65	65	--	6,10	GG
26	XH	200	3F	2517-60	183,92	198	65	65	--	7,40	GG
28	XH	200	5F	2517-60	198,10	212	65	65	--	9,00	GG
30	XH	200	5WF	2517-60	212,24	227	65	65	124	8,60	GG
32	XH	200	5WF	2517-60	226,39	240	65	65	124	9,80	GG
¹ 40	XH	200	5WF	3020-75	282,98	297	65	65	159	13,30	GG
48	XH	200	5W	3020-75	339,57	--	65	65	159	19,00	GG
60	XH	200	4A	3535-90	424,46	--	65	89	178	22,00	GG
72	XH	200	4A	3535-90	509,37	--	65	89	178	26,00	GG
84	XH	200	4A	3535-90	594,26	--	65	89	178	29,00	GG
96	XH	200	4A	3535-90	679,15	--	65	89	178	34,00	GG
120	XH	200	4A	3535-90	848,94	--	65	89	178	47,00	GG

* GG = gietijzer

TANDRIEMPOELIES

XH-300

- riem • steek $XH = 7/8" = 22,225$ mm
 • breedte $300 = 3" = 76,2$ mm

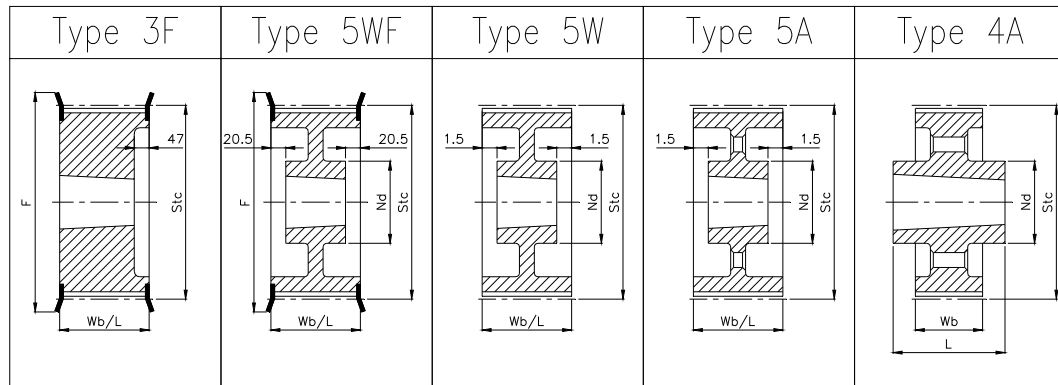

KTN CODE				¹ maat 47 = 41 mm							
Aantal Tandens <i>z</i>	Steek	Riem breedte	Type	Taper spanbussen + max. boring	Steek cirkel S1c [mm]	Flens diameter F [mm]	Wiel breedte Wb [mm]	Lengte L [mm]	Naaf diameter Nd [mm]	Gewicht ca. [kg/stuk]	Materiaal *
18	XH	300	3F	2517-60	127,33	142	92	92	--	3,70	GG
20	XH	300	3F	2517-60	141,48	155	92	92	--	4,70	GG
22	XH	300	3F	2517-60	155,63	170	92	92	--	6,00	GG
24	XH	300	3F	2517-60	169,80	184	92	92	--	7,60	GG
26	XH	300	3F	2517-60	183,92	198	92	92	--	11,60	GG
¹ 28	XH	300	3F	3020-75	198,10	212	92	92	--	9,80	GG
¹ 30	XH	300	3F	3020-75	212,24	227	92	92	--	11,90	GG
¹ 32	XH	300	3F	3020-75	226,39	240	92	92	--	13,80	GG
40	XH	300	5WF	3020-75	282,98	297	92	92	159	19,50	GG
48	XH	300	5W	3535-90	339,57	--	92	92	178	27,00	GG
60	XH	300	5A	3535-90	424,46	--	92	92	178	28,00	GG
72	XH	300	5A	3535-90	509,37	--	92	92	178	33,00	GG
84	XH	300	4A	4040-100	594,26	--	92	102	216	46,00	GG
96	XH	300	4A	4040-100	679,15	--	92	102	216	51,00	GG
120	XH	300	4A	4040-100	848,94	--	92	102	216	67,00	GG

* GG = gietijzer

TANDRIEMPOELIES

XH-400

riem • steek $XH = 7/8" = 22,225 \text{ mm}$
 • breedte $400 = 4" = 101,6 \text{ mm}$

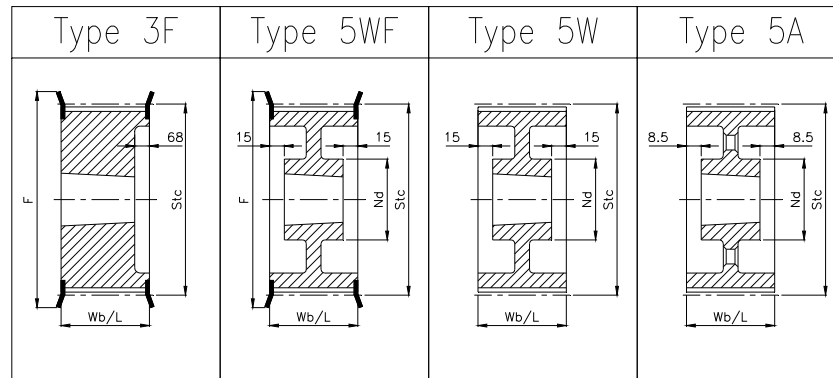

KTN CODE				¹ maat 68 = 74 mm							
Aantal Tandem z	Steek	Riem breedte	Type	Taper spanbussen + max. boring	Steek cirkel S1c [mm]	Flens diameter F [mm]	Wiel breedte Wb [mm]	Lengte L [mm]	Naaf diameter Nd [mm]	Gewicht ca. [kg/stuk]	Materiaal *
¹ 18	XH	400	3F	2517-60	127,33	142	119	119	--	4,60	GG
¹ 20	XH	400	3F	2517-60	141,48	155	119	119	--	6,00	GG
¹ 22	XH	400	3F	2517-60	155,63	170	119	119	--	7,20	GG
24	XH	400	3F	3020-75	169,80	184	119	119	--	8,40	GG
26	XH	400	3F	3020-75	183,92	198	119	119	--	10,30	GG
28	XH	400	3F	3020-75	198,10	212	119	119	--	12,30	GG
30	XH	400	3F	3020-75	212,24	227	119	119	--	14,30	GG
32	XH	400	3F	3020-75	226,39	240	119	119	--	19,90	GG
40	XH	400	5WF	3535-90	282,98	297	119	119	178	24,60	GG
48	XH	400	5W	3535-90	339,57	--	119	119	178	30,00	GG
60	XH	400	5A	4040-100	424,46	--	119	119	216	40,00	GG
72	XH	400	5A	4040-100	509,37	--	119	119	216	47,00	GG
84	XH	400	5A	4040-100	594,26	--	119	119	216	52,00	GG
96	XH	400	5A	4040-100	679,15	--	119	119	216	62,00	GG
120	XH	400	5A	4040-100	848,94	--	119	119	216	81,00	GG

* GG = gietijzer