

TRANSPORTKETTINGEN

Schraperkettingen DIN 8167 ISO 1977

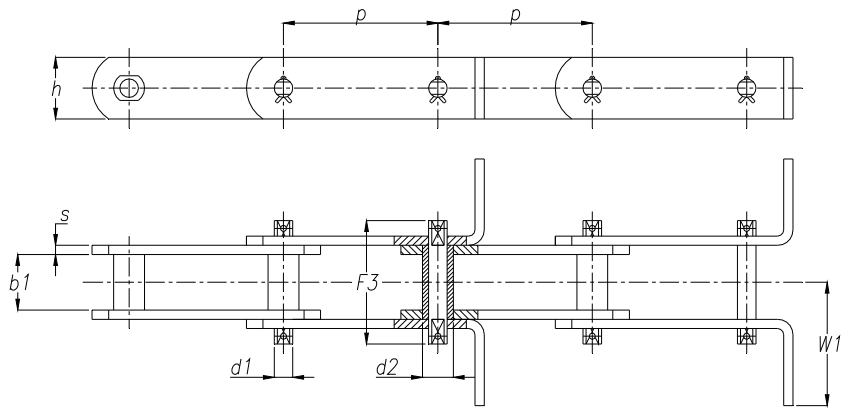

Ketting nummer	Steek p [mm]	Inwendige breedte b1 [mm]	Pen- diameter d1 [mm]	Bus- diameter d2 [mm]	Pen- lengte F3 [mm]	Plaat hoogte h [mm]	Plaat dikte s [mm]	W1~ [mm]	Schar- nierend opp. [cm ²]	Toegestane trek- belasting [kN]	Bruk belasting [kN]
TM 40	63 80 100 125 160 200 250	20	8,5	12,5	47,5	25	3,5	82	2,3	5,7	40
TM 56	63 80 100 125 160 200 250	24	10	15	56,5	30	4	95	3,2	8	56
TM 80	80 100 125 160 200 250 315	28	12	18	64,5	35	5	108	4,58	11,4	80
TM 112	80 100 125 160 200 250 315 400	32	15	21	75,5	40	6	120	6,63	16	112
TM 160	100 125 160 200 250 315 400 500	37	18	25	88,5	50	7	133	9,22	22,8	160
TM 224	125 160 200 250 315 400 500	43	21	30	99,5	60	8	158	12,47	32	224

TM 315 - TM 900 volgens klantspecificatie