

ROLLENKETTINGEN Langesteek

Europese uitvoering - BS

DIN 8181
ISO 1275
ANSI

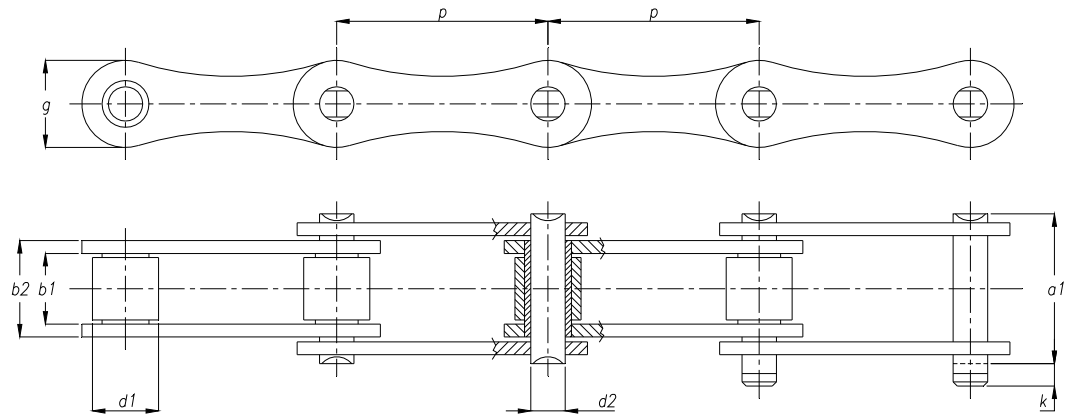

| K.T.N. nummer | Steek | | Inwendige breedte b1 min. [mm] | Rol-diameter d1 max. [mm] | b2 max. [mm] | Pen-diameter d2 h9 [mm] | a1 max. [mm] | k max. [mm] | g max. [mm] | Schar-nierend opp. [cm ²] | Breuk-belasting min. [kN] | Gewicht ca. [kg/m] |
|---------------|--------|-------|--|---|---------------------------|---|---------------------------|--------------------------|--------------------------|--|---------------------------------|--------------------------|
| | [inch] | [mm] | | | | | | | | | | |
| 208 B | 1 | 25,4 | 7,75 | 8,51 | 11,30 | 4,45 | 17,0 | 3,9 | 11,8 | 0,50 | 18,0 | 0,45 |
| 210 B | 1 1/4 | 31,75 | 9,65 | 10,16 | 13,28 | 5,08 | 19,6 | 4,1 | 14,7 | 0,67 | 22,4 | 0,65 |
| 212 B | 1 1/2 | 38,1 | 11,68 | 12,07 | 15,62 | 5,72 | 22,7 | 4,6 | 16,1 | 0,89 | 29,0 | 0,76 |
| 216 B | 2 | 50,8 | 17,02 | 15,88 | 25,45 | 8,28 | 36,1 | 5,4 | 21,0 | 2,10 | 60,0 | 1,75 |
| 220 B | 2 1/2 | 63,5 | 19,56 | 19,05 | 29,00 | 10,19 | 43,2 | 6,1 | 26,4 | 2,96 | 95,0 | 1,95 |
| 224 B | 3 | 76,2 | 25,40 | 25,40 | 37,90 | 14,63 | 53,4 | 6,6 | 33,4 | 5,54 | 160,0 | 4,50 |