

ROLLENKETTINGEN SIMPLEX

Amerikaanse norm

DIN 8188

ISO 606

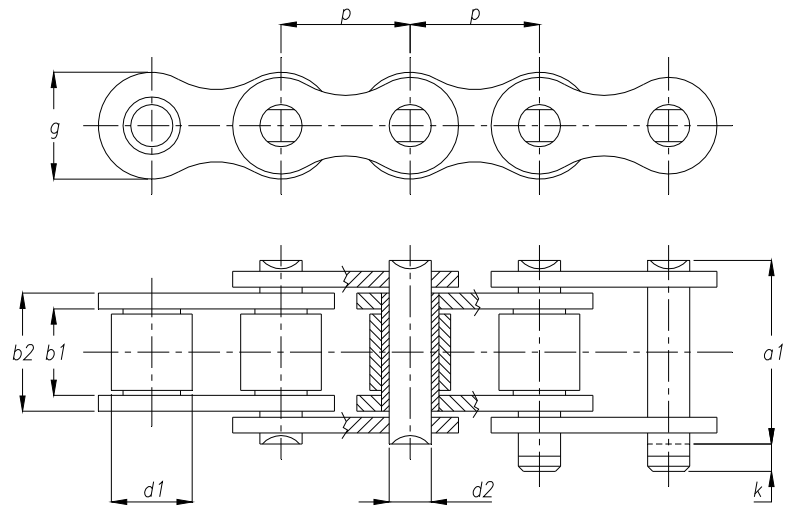

K.T.N. nummer	Steek		Inwendige breedte b1 min. [mm]	Rol- diameter d1 max. [mm]	b2 max. [mm]	Pen- diameter d2 h9 [mm]	a1 max. [mm]	k max. [mm]	g max. [mm]	Schar- nierend opp. [cm ²]	Breuk- belasting min. [kN]	Gewicht ca. [kg/m]
	p											
	[inch]	[mm]										
08 A-1	1/2	12,7	7,85	7,95	11,15	3,96	17,8	3,9	12,0	0,44	14,1	0,6
10 A-1	5/8	15,875	9,40	10,16	13,80	5,08	21,8	4,1	15,0	0,70	22,2	1,0
12 A-1	3/4	19,05	12,57	11,91	17,70	5,94	26,9	4,6	18,0	1,05	31,8	1,5
16 A-1	1	25,4	15,75	15,88	22,50	7,92	33,5	5,4	24,1	1,78	56,7	2,6
20 A-1	1 1/4	31,75	18,90	19,05	27,40	9,53	41,1	6,1	30,1	2,61	88,5	3,7
24 A-1	1 1/2	38,1	25,22	22,23	35,30	11,10	50,8	6,6	36,2	3,92	127,0	5,5
28 A-1	1 3/4	44,45	25,22	25,40	37,00	12,70	54,9	7,4	42,2	4,70	172,4	7,5
32 A-1	2	50,8	31,55	28,58	45,00	14,27	65,5	7,9	48,2	6,42	226,8	9,7
40 A-1	2 1/2	63,5	37,85	39,68	54,70	19,84	80,3	10,0	60,3	10,85	353,8	15,8
48 A-1	3	76,2	47,35	47,63	67,50	23,80	95,5	10,0	72,3	16,07	510,3	22,6

Tevens leverbaar in staal vernikkelde uitvoering.

ROLLENKETTINGEN DUPLEX

Amerikaanse norm

DIN 8188

ISO 606

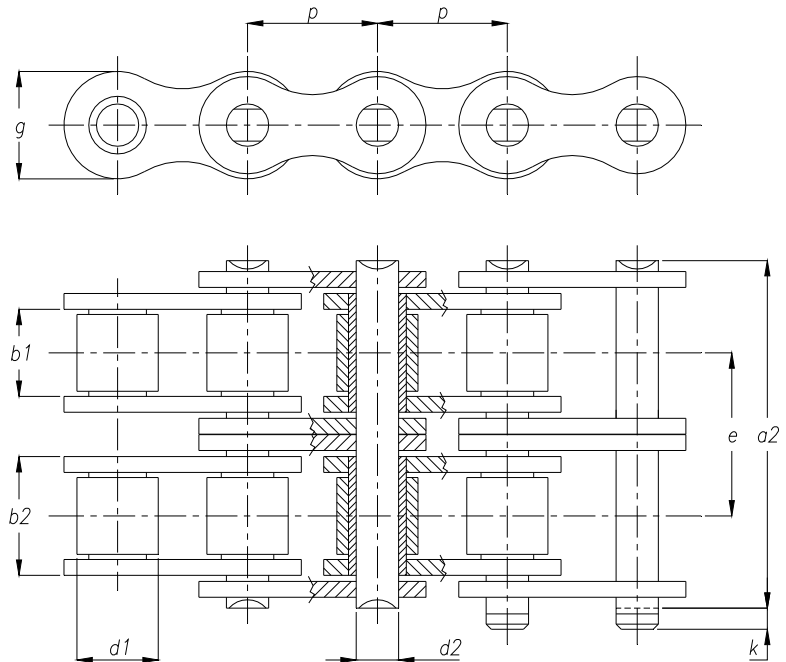

K.T.N. nummer	Steek		Inwendige breedte b1 min. [mm]	Rol- diameter d1 max. [mm]	b2 max. [mm]	Pen- diameter d2 h9 [mm]	e	a2 max. [mm]	k max. [mm]	g max. [mm]	Schar- nierend opp. [cm ²]	Breuk- belasting min. [kN]	Gewicht ca. [kg/m]
	[inch]	[mm]											
08 A-2	1/2	12,7	7,85	7,95	11,15	3,96	14,38	32,2	3,9	12,0	0,88	28,2	1,2
10 A-2	5/8	15,875	9,40	10,16	13,80	5,08	18,11	39,9	4,1	15,0	1,40	44,4	1,9
12 A-2	3/4	19,05	12,57	11,91	17,70	5,94	22,78	49,8	4,6	18,0	2,10	63,6	2,9
16 A-2	1	25,4	15,75	15,88	22,50	7,92	29,29	62,7	5,4	24,1	3,56	113,4	5,0
20 A-2	1 1/4	31,75	18,90	19,05	27,40	9,53	35,76	77,0	6,1	30,1	5,22	177,0	7,3
24 A-2	1 1/2	38,1	25,22	22,23	35,30	11,10	45,44	96,3	6,6	36,2	7,84	254,0	10,9
28 A-2	1 3/4	44,45	25,22	25,40	37,00	12,70	48,87	103,0	7,4	42,2	9,40	344,8	14,4
32 A-2	2	50,8	31,55	28,58	45,00	14,27	58,55	124,0	7,9	48,2	12,84	453,6	19,0
40 A-2	2 1/2	63,5	37,85	39,68	54,70	19,84	71,55	151,0	10,0	60,3	21,70	707,6	32,0
48 A-2	3	76,2	47,35	47,63	67,50	23,80	87,83	183,0	10,0	72,3	32,13	1.020,6	44,0

Tevens leverbaar in staal vernikkelde uitvoering.

ROLLENKETTINGEN TRIPLEX

Amerikaanse norm

DIN 8188

ISO 606

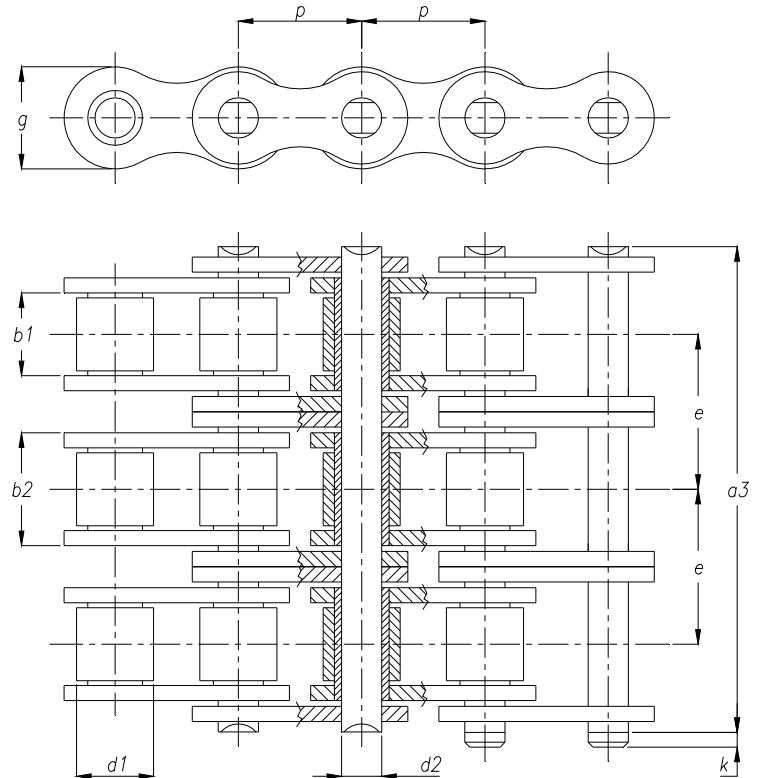

K.T.N. nummer	Steek		Inwendige breedte b1 min. [mm]	Rol- diameter		Pen- diameter d2 h9 [mm]	e	a3 max. [mm]	k max. [mm]	g max. [mm]	Schar- nierend opp. [cm ²]	Breuk- belasting min. [kN]	Gewicht ca. [kg/m]
	p			d1 max. [mm]	b2 max. [mm]								
	[inch]	[mm]	[mm]	[mm]	[mm]								
08 A-3	1/2	12,7	7,85	7,95	11,15	3,96	14,38	46,7	3,9	12,0	1,32	42,3	1,8
10 A-3	5/8	15,875	9,40	10,16	13,80	5,08	18,11	57,9	4,1	15,0	2,10	66,6	2,9
12 A-3	3/4	19,05	12,57	11,91	17,70	5,94	22,78	72,6	4,6	18,0	3,15	95,4	4,3
16 A-3	1	25,4	15,75	15,88	22,50	7,92	29,29	91,7	5,4	24,1	5,35	170,1	7,5
20 A-3	1 1/4	31,75	18,90	19,05	27,40	9,53	35,76	113,0	6,1	30,1	7,83	265,5	11,0
24 A-3	1 1/2	38,1	25,22	22,23	35,30	11,10	45,44	141,0	6,6	36,2	11,76	381,0	16,5
28 A-3	1 3/4	44,45	25,22	25,40	37,00	12,70	48,87	152,0	7,4	42,2	14,10	517,2	21,7
32 A-3	2	50,8	31,55	28,58	45,00	14,27	58,55	182,0	7,9	48,2	19,26	680,4	28,3
40 A-3	2 1/2	63,5	37,85	39,68	54,70	19,84	71,55	223,0	10,0	60,3	32,56	1.061,4	48,0
48 A-3	3	76,2	47,35	47,63	67,50	23,80	87,83	271,0	10,0	72,3	48,20	1.530,9	66,0

Tevens leverbaar in staal vernikkelde uitvoering.