

TRANSPORTKETTINGEN

Hollebout - Transportkettingen - MC

DIN 8168

ISO 1977

Ketting nummer	Steek p [mm]	Inwendige breedte b1 [mm]	b2 [mm]	b3 [mm]	Pen- diameter d1 [mm]	Bus- diameter d2 (O) [mm]	Rol- diameter d3 (A) [mm]	Rol- diameter d4 (B) [mm]
MC 28	63 80 100 125 160	20	28	28,3	13	17,5	25	36
MC 56	80 100 125 160 200 250	24	33	33,3	15,5	21	30	50
MC 112	100 125 160 200 250 315	32	45	45,5	22	29	42	70
MC 224	160 200 250 315 400 500	43	60	60,6	31	41	60	100

TRANSPORTKETTINGEN

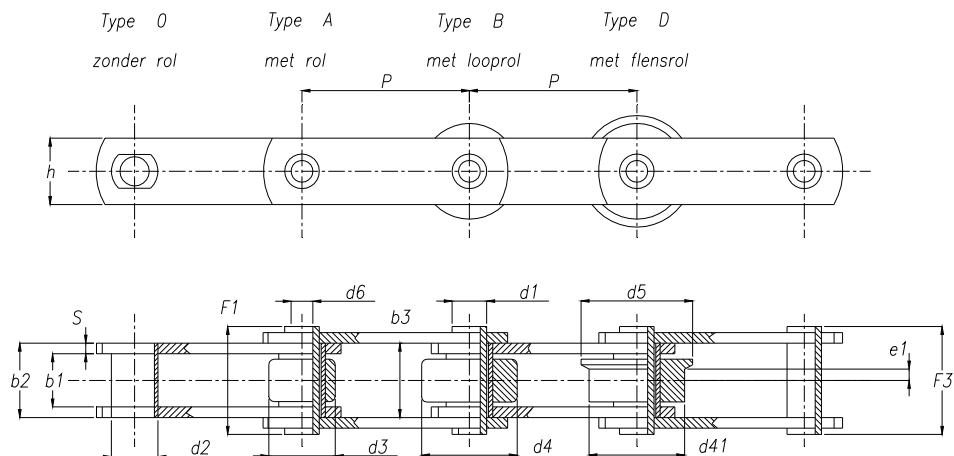

Flens / Rol diameter d41/d5 (D) [mm]	Hollebout boring d6 [mm]	e1 [mm]	Pen- lengte F1 [mm]	Pen- lengte F3 [mm]	Plaat hoogte h [mm]	Plaat dikte s [mm]	Schar- nierend opp. [cm ²]	Maximale Oppervlakte- druk [N/cm ²]	Breuk belasting [kN]
36 / 42	8,2	4,5	40,6	40,6	25	3,5	3,64	1100	28
50 / 60	10,2	6	46,6	46,6	35	4	5,11	1560	56
70 / 85	14,3	7,5	63,8	63,8	50	6	9,90	1610	112
100 / 120	20,3	10	82,9	82,9	70	8	18,60	1720	224